

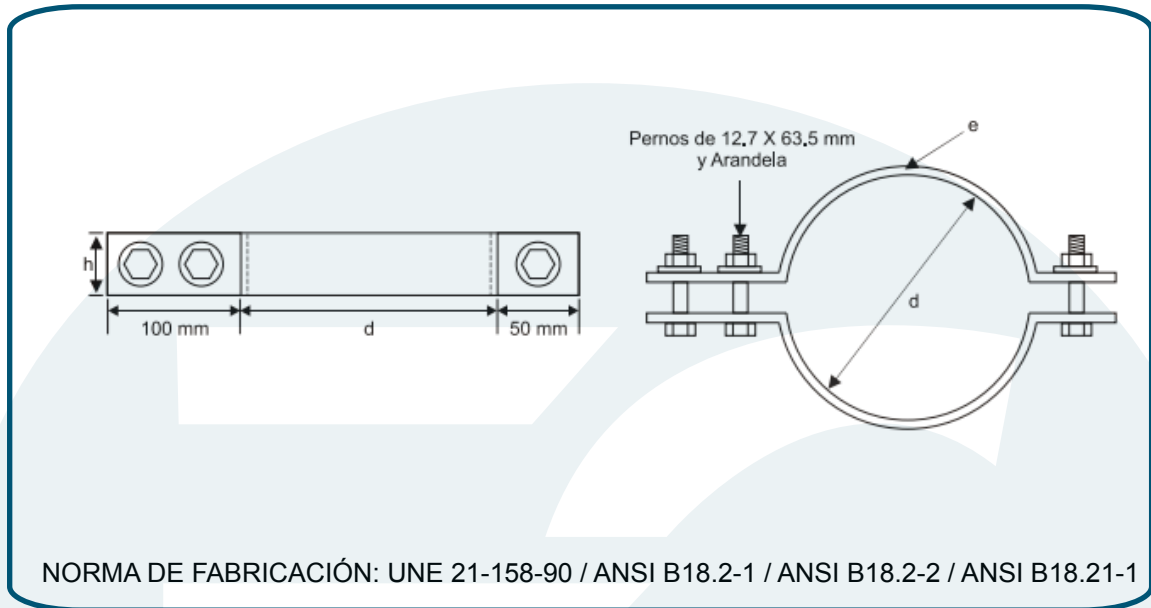

ElectroCASTILLO
COMPANY S.A.C.
FERRETERIA ELECTRICA E INDUSTRIAL

ABRAZADERA PARA RETENIDA



NORMA DE FABRICACIÓN: UNE 21-158-90 / ANSI B18.2-1 / ANSI B18.2-2 / ANSI B18.21-1

Características Técnicas

DIMENSIONES			PESO Kg
e	h	D(mm)	
4.5	50.8	100	1.30
		125	1.42
		150	1.60
		200	1.800
		220	2.05
		250	2.40
6.00	50.8	100	1.53
		125	1.68
		150	1.80
		200	2.10
		220	2.50
		250	2.90

*Suministro en otras medidas, a requerimiento

MATERIAL	ACABADO	ACCESORIOS
Acero SAE 1020	Galvanizado en caliente ASTM A-153	Pernos, tuercas y arandelas galvanizadas en caliente

Av. Franklin Roosevelt # 395- Cercado de Lima

☎ 428-9586 / 99833 4950 / 99803-11945

✉ ventas@electrocastillo.com

www.electrocastillo.com