

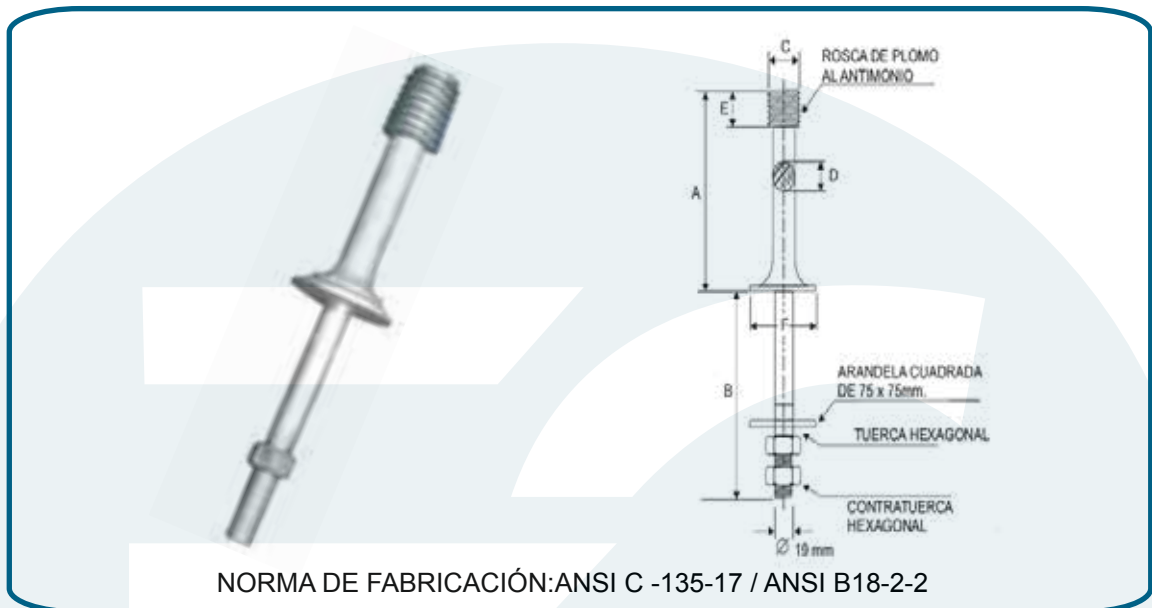

ElectroCASTILLO
COMPANY S.A.C.
FERRETERIA ELECTRICA E INDUSTRIAL

ESPIGA PARA CRUCETA



NORMA DE FABRICACIÓN: ANSI C -135-17 / ANSI B18-2-2

Características Técnicas

DIMENSIONES (mm)							RESISTENCIA A LA	PESO
ANSI	A	B	C	D	E	F	KN.	Kg.
55.5	152	153	25.4	19	54	63	6.2	1.450
56.2	180	176	35	19	54	63	9.81	1680.000
56.2	180	176	35	25	54	75	9.81	1.830
56.3	203	178	35	28.6	54	89	12.04	2.000
56.4	254	178	35	28.6	54	89	9.36	2.140

MATERIAL DE LA ROSCA	NORMA	ACABADO	NORMA
Plomo	ASTM - 153	Galvanizado en caliente	ANSI C135.17