

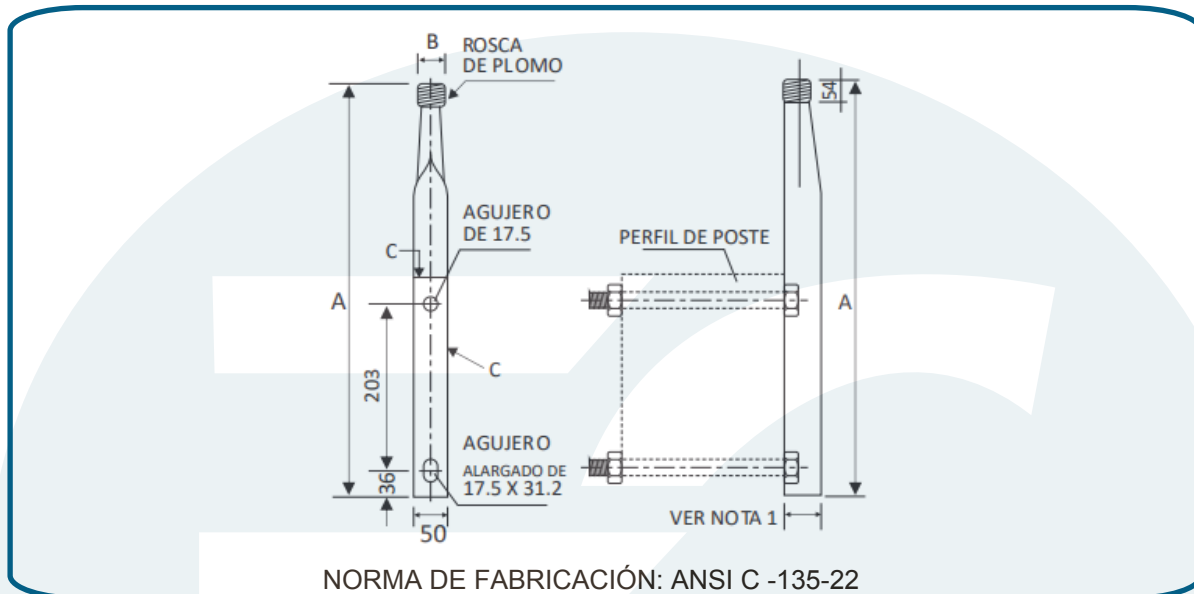

# ESPIGA PARA VÉRTICE DE POSTE



## Características Técnicas

DIMENSIONES (mm)				CARGA (KN)		PESO Kg.
ANSI	A	B	C	TRANS.	LONG	
55-5	508	25	4.5	6.47	5.4	1.52
56-2	508	35	4.5	6.47	5.4	1.52
56-3	609	35	4.5	6.47	5.4	1.8
56-4	609	35	4.5	6.47	5.4	1.8

MATERIAL	ACABADO
Acero SAE 1020	Galvanizado en caliente ASTM A-153