

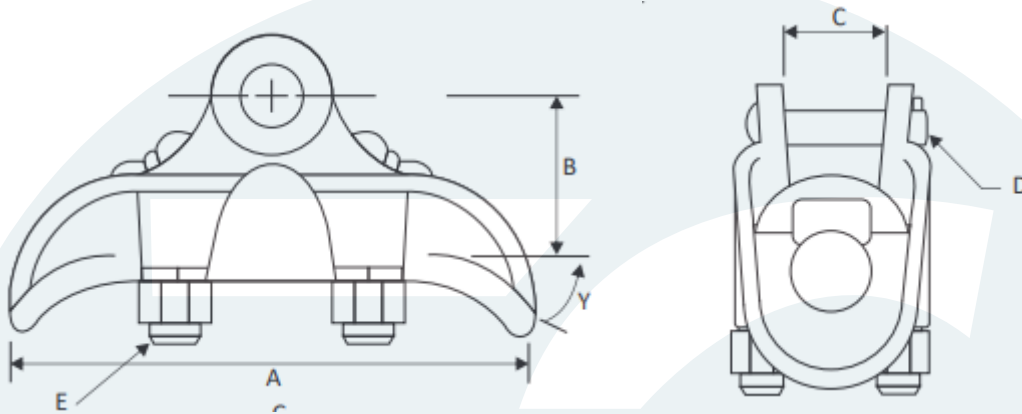

ElectroCASTILLO
COMPANY S.A.C.
FERRETERIA ELECTRICA E INDUSTRIAL

GRAPA DE SUSPENSIÓN DE F°G°



NORMA DE FABRICACIÓN: UNE 21-159 / ANSI B18.2-1 / ANSI B18.2-2 ANSI B18.21-1

Características Técnicas

RANGO DE CONDUCTORES		DIMENSIONES (mm)					ÁNGULO DE	U BOLTS	TORQUE	RESISTENCIA A LA ROTURA	PESO
Min	Max	A	B	C	D	E	Y	N°	N-m	KN	Kg
5.08	15.78	164.97	53.93	19	16	13	30°	2	45	71	1.60
6.35	19.05	164.97	57.1	22.2	16	13	30°	2	45	81	2.00
10.16	21.84	190.35	60.27	25.4	16	13	30°	2	45	81	2.90
10.16	26.67	190.35	63.45	28.55	16	13	30°	2	45	111	4.20

MATERIAL	ACABADO	ACCESORIOS
Hierro Nodular	Galvanizado en caliente ASTM A-153	Pin, U bolt, tuerca, arandelas y pasador

Av. Franklin Roosevelt # 395- Cercado de Lima

☎ 428-9586 / 99833 4950 / 99803-11945

✉ ventas@electrocastillo.com

www.electrocastillo.com