

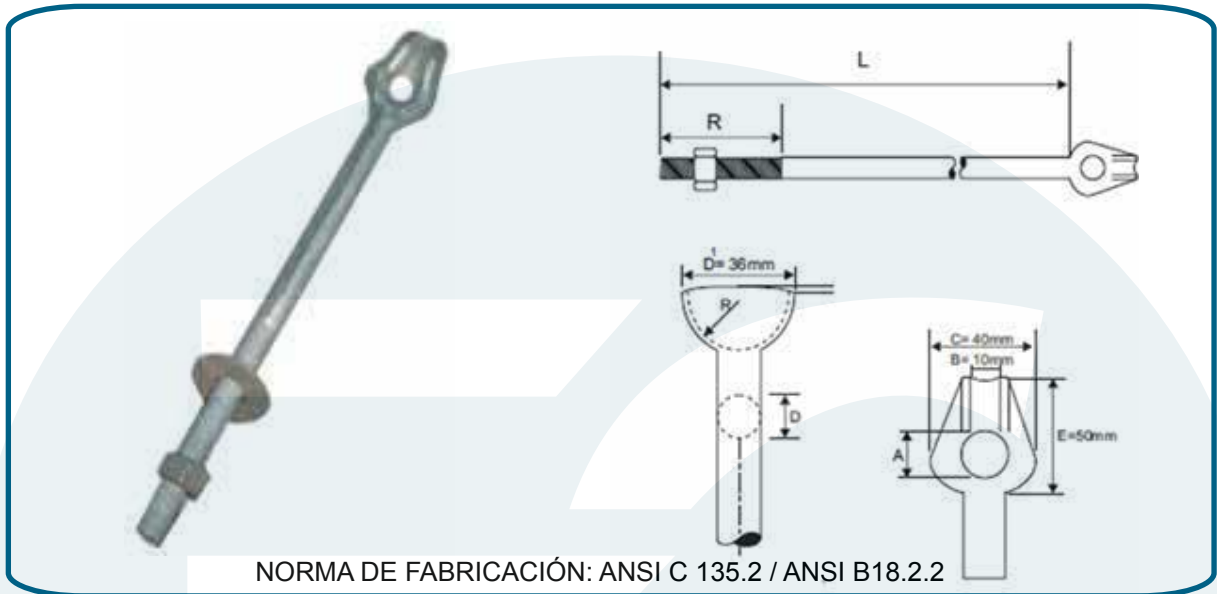

ElectroCASTILLO
COMPANY S.A.C.
FERRETERIA ELECTRICA E INDUSTRIAL

VARILLA DE ANCLAJE



Características Técnicas

DIMENSIONES mm.				PESO Kg.
Lmm	Ø Dmm.	R	CARGA MINIMA DE TRACCIÓN	
1800	13 (1/2")	100	51 KN	1.4
1800	16(5/8")	100	51 KN	3.04
2400	16(5/8")	100	51 KN	4.05
2400	19(3/4")	100	51 KN	5.70

MATERIAL	ACABADO	NORMA DE FABRICACION
Acero SAE 1020	Galvanizado en caliente ASTM A-153	ANSI C 135.2

Av. Franklin Roosevelt # 395- Cercado de Lima

☎ 428-9586 / 99833 4950 / 99803-11945

✉ ventas@electrocastillo.com

www.electrocastillo.com